

INVESTMENT CASTING

COMPLETE IN-HOUSE DESIGN & PRODUCTION



pbsindia.com



INVESTMENT CASTING

PBS, a Czech company with a 200-year history, has been specializing in investment casting since 1969 and is the European leader in this technology. We focus on precision castings of superalloys as wheels for turbochargers, blades for gas turbines, impellers and guide wheels for aircraft engines and many other types of castings for various industrial sectors.

Our advanced technologies, including vacuum and open furnaces, enable us to produce a wide range of materials, including steel alloys. With a reputation for reliability and expertise, we continually evolve to meet our customers' needs and deliver high quality products.



OUR CONTRIBUTION TO MUTUAL COOPERATION

- ✓ More than 50 years of experience in investment casting
- ✓ Internal research and development capabilities
- ✓ In-house testing laboratory
- ✓ More than 100,000 highly precise complex investment castings per year

WHY PBS

- ✓ We provide everything from design, casting and machining to the final product
- ✓ From carbon steels to nickel or cobalt superalloys
- ✓ Technically advanced products with high durability
- ✓ Reverse engineering and rapid prototyping
- ✓ For several decades, we have been cooperating with leading world manufacturers of turbochargers, combustion turbines, aviation components and insulation materials based on glass wool



PRODUCTION POSSIBILITIES

- ✓ Dimension range of casts: 30 - 600 mm
- ✓ Weight range of casts: 0.15 - 50 kg
- ✓ Superalloys
- ✓ Air or vacuum casting
- ✓ Surface roughness: Ra 3,2 μm

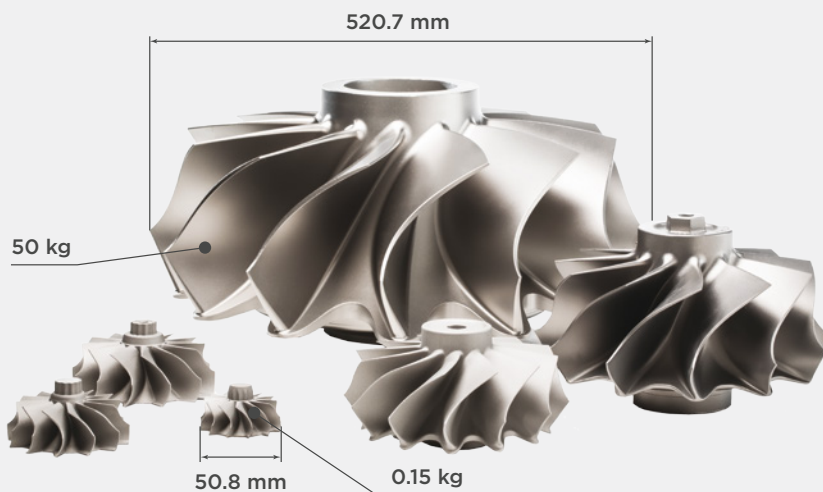

INC 713
INC 738
MAR M247
B1914



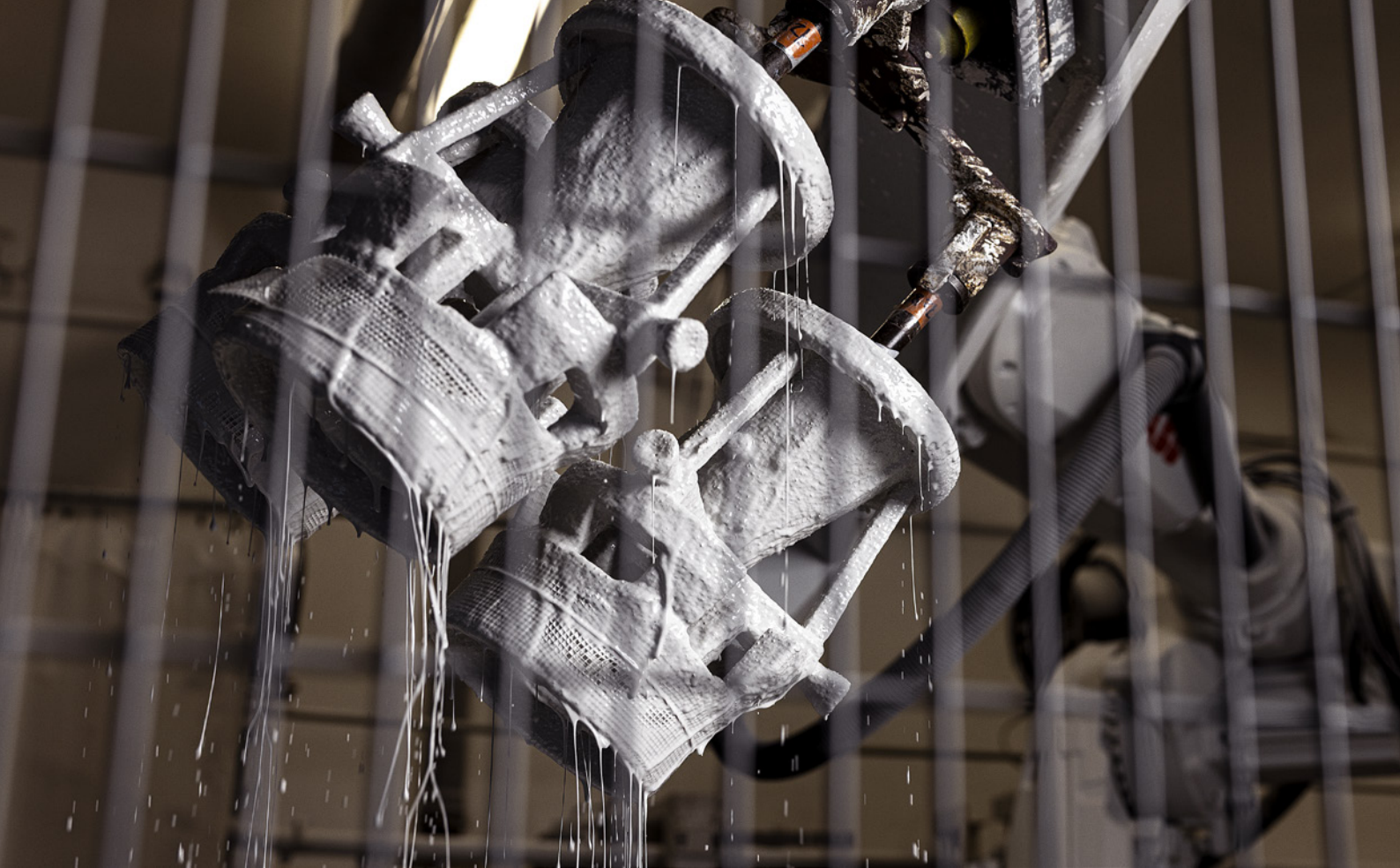

PRODUCTION PROCESS

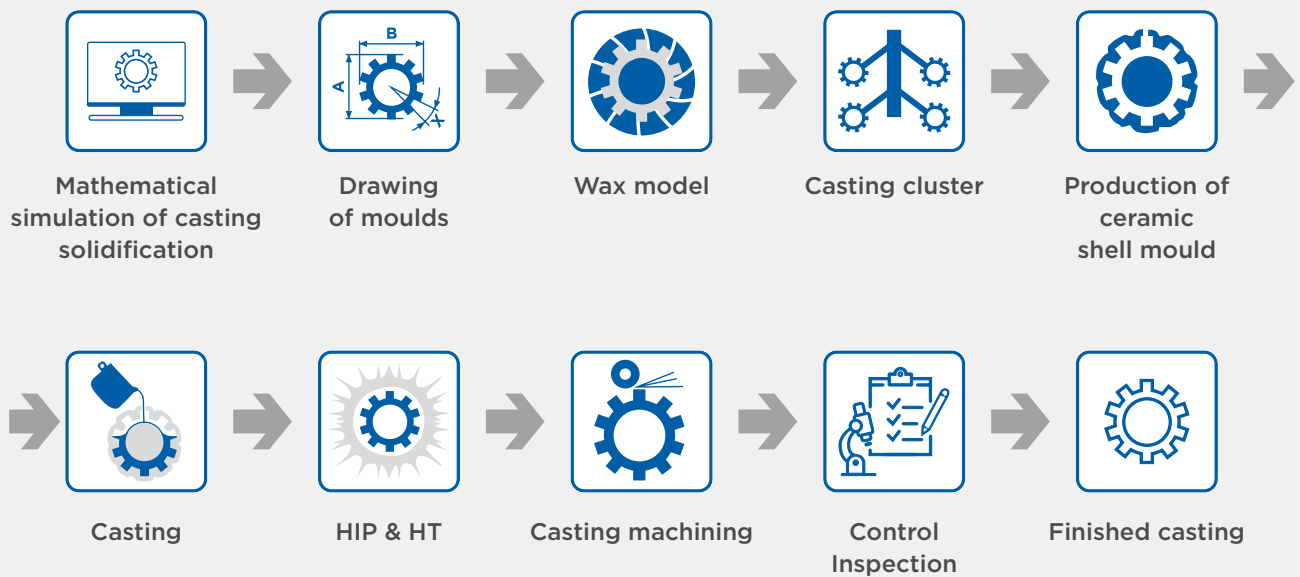

PRODUCT PORTFOLIO

For several decades we cooperate with leading world manufacturers of turbochargers, combustion turbines, aviation components and insulation materials based on glass wool. An individual approach to each customer is important to us.

TRANSPORTATION	POWER INDUSTRY	AEROSPACE	INSULATING MATERIALS	HEALTHCARE
Turbocharger wheels and blades	Gas turbine buckets and nozzles	Impeller and guide wheels for aircraft engines, APU and casting parts for ECS	Spinner discs	Knee replacements
Wheel diameter: 50-400 mm	Blade length: 50-400 mm	Impeller diameter: 60-260 mm	Spinner disc diameter: 300-520 mm	Shape: Anatomically-shaped component, L and R version
Wheel weight: 0.15-44 kg	Blade weight: max. 35 kg	Impeller weight: max. 2.5 kg	Spinner disc weight: 9-30 kg	Size: Wide size range (six sizes)
Material used: IN 713C, IN 713LC, B1914, MAR M247	Material used: EEQ 111, FSX 414, IN 939, IN 738LC, MAR M247	Material used: IN 713LC, MAR M247, IN 792-5A	Material used: Ni and Co based superalloys for glass industry: 141I, 141J, 2.4879, Co Stellite	Material used: Cobalt alloy CoCrMo (ISO 5832-4)



FOUNDRY TECHNOLOGY

- ✓ 10 injection moulding machines
- ✓ 2 robotic coating lines
- ✓ 2 boilerclaves for smelting
- ✓ 4 carousel gas annealing furnaces
- ✓ 2 electronic resistance annealing furnaces
- ✓ 7 vacuum furnaces
- ✓ 9 blasting machines

ADDITIONAL SERVICES

- ✓ Special types of heat treatment
 - In a protective atmosphere of argon, nitrogen or vacuum
 - Hot isostatic pressing (HIP)
- ✓ Machining and balancing
- ✓ Production of model equipment
- ✓ Removing ceramic cores in a leaching autoclave
- ✓ 3D measurement
- ✓ Testing in our own or independent laboratories
- ✓ Non-destructive tests certified by NADCAP

ABOUT US

PBS is a globally recognized engineering brand with a history of over two hundred years.

The company specializes in the R&D and manufacturing of turbine engines, APUs, and ECS systems designed for unmanned aerial vehicles, medium helicopters, and airplanes.

PBS also develops and produces cryogenic equipment for the world's largest manufacturers of gas liquefaction systems.

PBS Foundry is one of the leading suppliers of nickel and cobalt-based superalloy castings in Europe.



DOA



POA & MOA



AS 9100,
ISO 9001 & ISO 14001



Non-destructive
testing (PT, RT)



pbsindia.com



info@pbsindia.com



ICA-IN06B-2604